

SAMPLE PAPER - 4

Class 10 - Science

Time Allowed: 3 hours

Maximum Marks: 80

General Instructions:

1. This question paper consists of 39 questions in 5 sections.
2. All questions are compulsory. However, an internal choice is provided in some questions. A student is expected to attempt only one of these questions.
3. Section A consists of 20 objective type questions carrying 1 mark each.
4. Section B consists of 6 Very Short questions carrying 02 marks each. Answers to these questions should in the range of 30 to 50 words.
5. Section C consists of 7 Short Answer type questions carrying 03 marks each. Answers to these questions should in the range of 50 to 80 words.
6. Section D consists of 3 Long Answer type questions carrying 05 marks each. Answer to these questions should be in the range of 80 to 120 words.
7. Section E consists of 3 source-based/case-based units of assessment of 04 marks each with sub-parts

Section A

1. A current of 1 A is drawn by a filament of an electric bulb. Number of electrons passing through a cross section of the filament in 16 seconds would be roughly [1]
 - a) 10^{23}
 - b) 10^{16}
 - c) 10^{18}
 - d) 10^{20}
2. The number of pair (s) of sex chromosomes in the zygote of humans is [1]
 - a) two
 - b) one
 - c) three
 - d) four
3. The xylem in plants are responsible for: [1]
 - a) transport of amino acids
 - b) transport of oxygen
 - c) transport of food
 - d) transport of water
4. An electron enters a magnetic field at right angles to it, as shown in Fig. The direction of force acting on the electron will be [1]

a) 5 A

b) 30 A

c) 0.5 A

d) 0.3 A

13. In the set-up shown below, a clear image of a distant object is obtained on the screen. The focal length of the concave mirror is: [1]

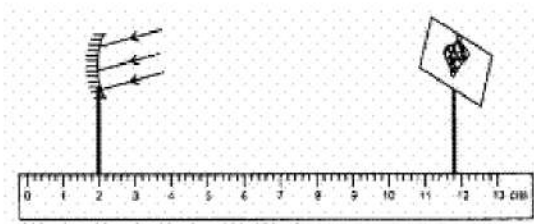

a) 9.4 cm

b) 9.9 cm

c) 9.8 cm

d) 11.4 cm

14. Sodium metal is stored in: [1]

a) Alcohol

b) Water

c) Ether

d) Kerosene

15. In an airtight experimental set-up which was used by you in the laboratory to study respiration in germinating seeds, the seeds obtained the oxygen for respiration from [1]

a) water in the germinating seeds

b) water in the beaker

c) water used for soaking the seeds

d) air in the flask

16. In which of the following animals external fertilization takes place? [1]

a) Fish and frog

b) Donkey and fish

c) Man and snake

d) Hen and dog

17. **Assertion (A):** A solenoid tends to expand, when a current passes through it. [1]

Reason (R): Two straight parallel metallic wires carrying current in same direction attract each other.

a) Both A and R are true and R is the correct explanation of A.

b) Both A and R are true but R is not the correct explanation of A.

c) A is true but R is false.

d) A is false but R is true.

18. **Assertion (A):** Plaster of Paris is used by doctors by setting fractured bones. [1]

Reason (R): When Plaster of Paris is mixed with water and applied around the fractured limbs, it sets into a hard mass.

a) Both A and R are true and R is the correct explanation of A.

b) Both A and R are true but R is not the correct explanation of A.

c) A is true but R is false.

d) A is false but R is true.

19. **Assertion (A):** Seismonastic movement shown by Mimosa pudica plant. [1]

Reason (R): It is due to change in turgidity of cells of pulvinus.

a) Both A and R are true and R is the correct explanation of A.

b) Both A and R are true but R is not the correct explanation of A.

c) A is true but R is false.

d) A is false but R is true.

20. **Assertion (A):** The concentration of harmful chemicals is more in human beings. [1]

Reason (R): Man is at the apex of the food chain.

- a) Both A and R are true and R is the correct explanation of A. b) Both A and R are true but R is not the correct explanation of A.
- c) A is true but R is false. d) A is false but R is true.

Section B

21. Element forming ionic compounds attain noble gas configuration by either gaining or losing electrons from their valence shells. Explain giving reason why carbon cannot attain such a configuration in this manner to form its compounds. Name the type of bonds formed in ionic compounds and in the compounds formed by carbon. Also explain with reason why carbon compounds are generally poor conductors of electricity. [2]

OR

People use a variety of methods to wash clothes. Usually after adding the soap, they 'beat' the clothes on a stone, or beat it with a paddle, scrub with a brush or the mixture is agitated necessary to get clean clothes?

22. i. Identify the endocrine glands A, B, C and D in the given diagram. [2]
ii. List the functions of parts D and E.

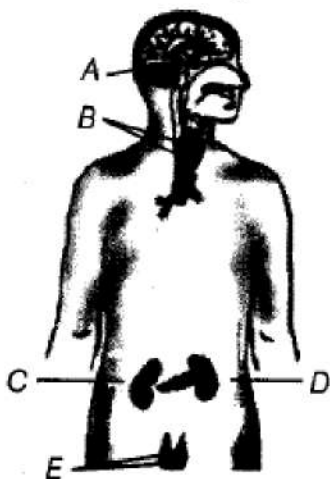

23. We often observe domestic waste decomposing in the bylanes of residential colonies. Suggest ways to make people realise that the improper disposal of waste is harmful to the environment. [2]
24. Draw a sequence of suitable methods of disposal of waste produced at your home to minimise environmental pollution. [2]
25. Name a mirror which can give an erect and enlarged image of an object. [2]

OR

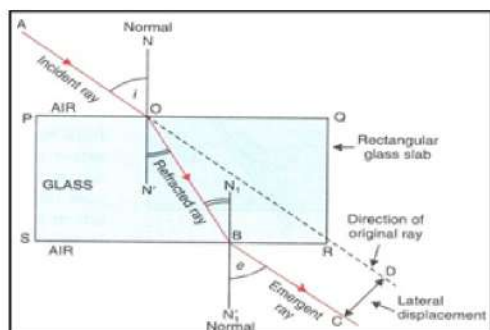

- i. Name the phenomenon.
- ii. Write the laws of the following phenomenon that depicts in the above figure.
- iii. Refractive index of diamond with respect to glass is 1.6. If the absolute refractive index of glass is 1.5. Find out the absolute refractive index of the diamond?

26. How many electrons are shared by each atom in the formation of [2]
(i) a double bond and
(ii) a triple bond?

Section C

27. What happens when dilute hydrochloric acid is added to iron filings? [3]
28. What is atmospheric refraction? Explain with the help of a labelled diagram that the position of a star as seen by us is not its true position. [3]
29. DNA copies generated during reproduction will be similar but may not be identical to the original. justify this statement. [3]

OR

Fertilization is possible if copulation has taken place during middle of menstrual cycle. Give reason.

30. i. State two main causes of a person developing near-sightedness. With the help of a ray diagram, suggest how he can be helped to overcome his disability? [3]
ii. The far point of myopic person is 100 cm in front of the eye. Calculate the focal length and power of a lens required to enable him to see distant objects clearly.
31. i. Why are the chips packets puffed when we buy them from market? [3]
ii. Paint is applied on articles made up of iron, why?
32. In human beings blue eye colour is recessive to brown eye colour. A brown eyed man has a blue eyed mother. [3]
a. What is the genotype of man and his mother?
b. What are possible genotypes of his father?
c. If man marries a blue eyed woman, what are the possible genotypes of their offsprings?

OR

In a pea plant, find the contrasting trait if

- i. the position of flower is terminal
ii. the flower is white in colour
iii. shape of pod is constricted
33. Why do we observe difference in colours of the Sun during sunrise, sunset and noon? [3]

Section D

34. i. An ore, on heating in air, give sulphur dioxide gas. Name the method in each metallurgical step, that will be required to extract this metal from its ore. [5]
ii. State which of the following reactions will take place or which will not, giving suitable reason for each?
a. $\text{Zn(s)} + \text{CuSO}_4(\text{aq}) \rightarrow \text{ZnSO}_4(\text{aq}) + \text{Cu(s)}$
b. $\text{Fe(s)} + \text{ZnSO}_4(\text{aq}) \rightarrow \text{FeSO}_4(\text{aq}) + \text{Zn(s)}$

OR

An alkali metal A gives a compound B (molecular mass = 40) on reacting with water. The compound B gives a soluble compound C on treatment with aluminium oxide. Identify A, B and C and give the reactions involved.

35. The labelled diagram of the excretory system in humans is shown below: [5]

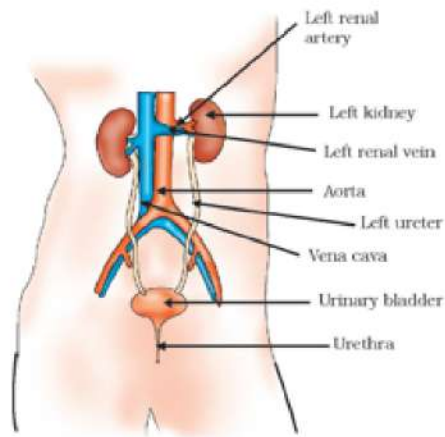

Diagram: Excretory System in Human Beings

Using the above diagram, answer the following questions:

- i. Where are kidneys located?
- ii. What is the function of the human excretory system?
- iii. Where is urine stored until it is released out of the body?
- iv. Which substances present in the blood pass into Bowman's capsule during filtration?
- v. What waste substances are present in the urine?

OR

Give the role of liver in the human beings.

36. Study the following current-time graphs from two different sources:

[5]

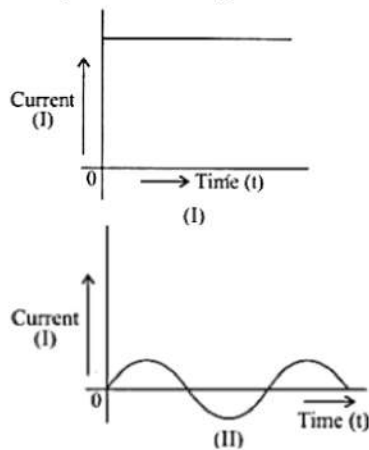

- a. Use above graphs to list two differences between the current in the two cases.
- b. Identify one source each for these currents.

Section E

37. Read the text carefully and answer the questions:

[4]

Two or more resistances are connected in series or in parallel or both, depending upon whether we want to increase or decrease the circuit resistance.

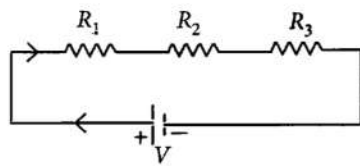

The two or more resistances are said to be connected in series if the current flowing through each resistor is the same.

- (i) When the three resistors each of resistance R ohm are connected in series then what will be the equivalent resistance?

- (ii) There is a wire of length 20 cm and having resistance $20\ \Omega$ cut into 4 equal pieces and then joined in series. What is equivalent resistance?

OR

In the following circuit, find the equivalent resistance between A and B ($R = 2\ \Omega$)

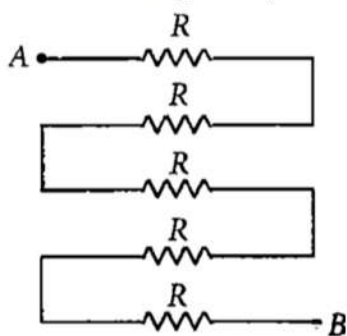

38. **Read the text carefully and answer the questions:**

[4]

You must have noticed many dramatic changes in your appearance as well as that of your friends as you approached 10-12 years of age. These changes associated with puberty are because of the secretion of testosterone in males and oestrogen in females. Do you know anyone in your family or friends who has been advised by the doctor to take less sugar in their diet because they are suffering from diabetes? As a treatment, they might be taking injections of insulin. This is a hormone that is produced by the pancreas.

- (i) Why is pancreas a dual gland?
- (ii) Name the hormone which is secreted by males and females during adolescence.
- (iii) What happens if Insulin is not secreted in the proper amount?

OR

From which cells of pancreatic islets insulin and glucagon hormone are secreted?

39. **Read the text carefully and answer the questions:**

[4]

Salt of a strong acid and strong base is neutral with a pH value of 7. NaCl common salt is formed by a combination of hydrochloride and sodium hydroxide solution. This is the salt that is used in food. Some salt is called rock salt, bed of rock salt was formed when seas of bygone ages dried up. The common salt thus obtained is an important raw material for various materials of daily use, such as sodium hydroxide, baking soda, washing soda, and bleaching powder.

- (i) If given acids are phosphoric acid, carbonic acid, hydrochloric acid and sulphuric acid, then which acid does not form an acidic salt?
- (ii) What is the formula of baking soda?
- (iii) Name the substance which on treatment with chlorine to obtain bleaching powder.

OR

Which salt is used for removing the permanent hardness of water?

Solution
SAMPLE PAPER - 4
Class 10 - Science
Section A

1. (d) 10^{20}

Explanation: We have current $I = 1 \text{ A}$ and time $t = 16\text{s}$

We know $I = \frac{Q}{t}$ or, $1. \text{ A} = \frac{Q}{16\text{s}}$

or, $Q = 16 \text{ C}$

Charge contained in 1 electron = $16 \times 10^{-19} \text{ C}$

So, 16 C charge is contained in the following number of electrons:

$$= \frac{1}{1.6 \times 10^{-18}} \times 16 = 10^{20}$$

2. (b) one

Explanation: A zygote has 23 pairs of chromosomes i.e., 46. Out of them, one pair is the sex chromosome.

3. (d) transport of water

Explanation: Xylem, plant vascular tissue that conveys water and dissolved minerals from the roots to the rest of the plant and also provides physical support. Xylem tissue consists of a variety of specialized, water-conducting cells known as tracheary elements, which help it to transport water throughout the plant.

4. (a) into the page.

Explanation: The direction of force is perpendicular to the direction of the magnetic field and current as given by Fleming's left-hand rule. Recall that the direction of current is taken opposite to the direction of motion of electrons. The force is therefore directed into the page.

5. (a) Hg

Explanation: All metals are solid at room temperature except for mercury. Mercury metal exists as a liquid at room temperature.

6. (d) Ethyl alcohol

Explanation: Ethyl alcohol

7. (a) Acidic

Explanation: $\text{pH} = -\log [\text{H}^+]$

So, $\text{pH}=5$ which shows that the solution is slightly acidic.

8. (c) I and IV

Explanation: Yeast and Hydra reproduced by budding. A younger growth on the parent organism is seen.

9. (c) natural indicator

Explanation: An indicator prepared from natural substances is known as a natural indicator. Examples are Litmus, Turmeric, China rose petals, Snowball plant, Red Cabbage, and Grape Juice. Litmus is a purple dye obtained from a plant lichen.

10. (c) Gram, pea and ground-nut

Explanation: Gram, pea and ground-nut

11. (d) Alleles

Explanation: An alternative form of a gene is known as an allele. Alleles vary in their sequence which may or may not result in a variant phenotype of a particular trait. Alleles represent variations of a gene that is responsible for a particular trait.

12. (c) 0.5 A

Explanation: Given,

Charge moved = 300 C

Time taken = 10 mins

Current = ?

$$I = \frac{Q}{t}$$

Substituting, we get $I = 0.5 \text{ A}$

13. (c) 9.8 cm
Explanation: $f = 11.8 - 2 = 9.8$ cm
14. (d) Kerosene
Explanation: Kerosene
15. (d) air in the flask
Explanation: The germinating seeds in the conical flask release CO_2 during respiration, which is absorbed by the KOH solution kept in the small test tube. This creates a partial vacuum in the flask that forces the water up the delivery tube. Thus, it proves that germinating seeds produce carbon dioxide during respiration.
16. (a) Fish and frog
Explanation: External fertilization is a male organism's sperm fertilizing a female organism's egg outside of the female's body. The female and male of fish and frogs both release their gametes into the water, where they diffuse together and fertilize
17. (d) A is false but R is true.
Explanation: When current flows through a solenoid, the currents in the various turns of the solenoid are parallel and in the same direction. Since the current flowing through parallel wires in the same direction lead to force of attraction between them, the turns of the solenoid will also attract each other and as a result the solenoid tends to contract.
18. (a) Both A and R are true and R is the correct explanation of A.
Explanation: Plaster of Paris when mixed with water and applied around the fractured limbs, sets into a hard mass and keeps the bone joints in a fixed position. So, it is commonly used for setting fractured bones.
19. (a) Both A and R are true and R is the correct explanation of A.
Explanation: Both A and R are true and R is the correct explanation of A.
20. (a) Both A and R are true and R is the correct explanation of A.
Explanation: Harmful chemicals accumulate progressively at each trophic level. Since man is at the apex of all the food chains, the concentration of harmful chemicals may be more in human beings. The phenomenon involved is known as biomagnification.

Section B

21. Carbon needs 4 electrons to complete its octet. It has 4 electrons in its valence shell. Thus, carbon can either gain or lose 4 electrons. But due to energy consideration, it is not possible. Therefore, in place of gaining or losing 4 electrons, carbon does sharing of these 4 electrons to form 4 covalent bonds.
Electrovalent or ionic bond is present in ionic compounds whereas covalent bond is present in Carbon compounds. Carbon compounds are poor conductors of electricity because of absence of ions.

OR

It is necessary to beat the cloth on stone or beat it with the paddle. Scrub it with a brush and mixture is agitated in the washing machine because the dirt particles are trapped in the clothes and to get them out we put the clothes in a water contain soap so the long hydrocarbons part of the missels present in soapy water are attached to the dirt particles and the ionic part of the missels are remain attached to the water. Then we beat the cloth on stone and Scrub it with a brush so that the long hydrocarbons came out with the stubborn dirt particles.

22. i. A - Pituitary present in brain. B -Thyroid, C- Adrenal and D-Pancreas.
ii. D - **Pancreas** : Pancreas regulates sugar metabolism and secretes insulin, which maintains blood sugar level.
E- **Testis** : Testis secrete testosterone, which controls sperm production and secondary sexual characters in males.
23. i. Banners and signboards indicating ill effects of improper waste disposal should be used to educate people.
ii. Street plays can be organised highlighting this issue.
24. The household waste produced from various activities is called garbage and its proper disposal is done in such a way that it does not cause environmental pollution.
Methods of waste disposal include:
- Recycling : The processing of certain wastes to form new products is called recycling, e.g. paper, glass etc., are recyclable.
 - Composting : It is the process of collecting biodegradable wastes like leftovers of food items, peels, etc. and burying them in a pit and using it as manure.
 - Incineration : It is burning of a substance at high temperature to reduce it to ashes.
 - Landfills : Dumping of non-biodegradable waste in low-lying areas is called landfill.
 - Sewage treatment : In sewage treatment plants, the sewage is processed and decomposed into simpler inorganic chemicals.

25. Concave mirror produces an erect and enlarged image when the object is placed between pole and focus as shown in the figure.

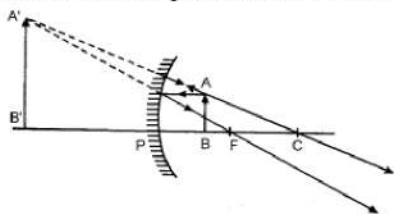

OR

i. Refraction of light through a rectangular glass slab.

ii. The following are the laws of refraction of light:

- The incident ray, the refracted ray and the normal to the interface of two transparent media at the point of incidence, all lie in the same plane.
- The ratio of the sine of the angle of incidence to the sine of the angle of refraction is a constant, for the light of a given colour and for the given pair of media. This law is also known as Snell's law of refraction.

iii. Given, ${}_d\mu_g = 1.6$ and $\mu_g = 1.5$

$$\text{Refractive index of diamond with respect to glass} = \frac{\text{Absolute refractive index of diamond}}{\text{Absolute refractive index of glass} (\mu_g)}$$

So, the absolute refractive index of diamond = Refractive index of diamond glass (${}_d\mu_g$) \times Absolute refractive index of diamond glass (μ_g) $\mu_d = 1.6 \times 1.5 = 2.4$

26. The electrons shared during the formation of:

i) **A double bond** - Two pairs of electron in which each atom contributes two electrons.

ii) **A triple bond** - Three pairs of electrons in which each atom contributes three electrons.

Section C

27. Hydrogen gas and Iron chloride are produced.



This is a redox reaction

$\text{Fe}(0) - 2\text{e}^- \rightarrow \text{Fe}(\text{II})$ oxidation loss of electrons

$2\text{H}^+ + 2\text{e}^- \rightarrow \text{H}_2$ reduction: gain of electrons

So it is certainly a chemical reaction: bonds are broken and made.

HCl is not a sufficiently strong oxidizing agent to produce FeCl_3 (need Cl_2).

28. **Atmospheric refraction:**- The refraction of light caused by the earth's atmosphere (having their layers of varying optical densities) is called atmospheric refraction.

Light from a star is refracted as it leaves space and enters the earth's atmosphere. Air higher up in the sky is rare but that near the Earth's surface is denser. So, as the light from a star comes down the dense air bends the light more. Therefore, the apparent position to the star is slightly different from its actual position.

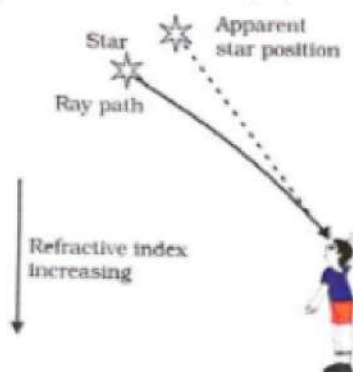

29. DNA copies generated will be similar, but may not be identical to the original as some variations are so drastic that new DNA copy cannot work with the cellular apparatus it inherits. Such a newborn cell will simply die. Therefore, there could be many other variations in the DNA copies that would not lead to such a drastic outcome. Thus, the surviving cells are similar but slightly different from each other. This tendency of variation during reproduction is the basis for evolution.

OR

Fertilization takes place in the fallopian tube only if mature ovum is released. In a normal menstrual cycle, ovulation occurs during middle of sexual cycle. Thus if copulation occurs only during this period only then fertilization is possible.

30. i. Near sightedness (myopia) defect arises either because of :
 (a) decrease in focal length of eye lens.(b) elongation of the eye ball
 ii. To correct this defect of vision, he must use a concave lens of suitable focal length. The concave lens of suitable focal length will bring the image back to the retina as shown in the given figure.

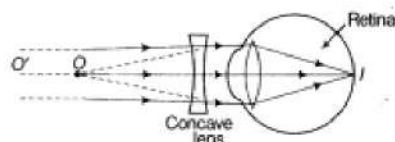

iii. Given, $v = -100 \text{ cm}$, $u = \infty$

Using lens formula,

$$\frac{1}{f} = \frac{1}{v} - \frac{1}{u} \Rightarrow \frac{1}{f} = \frac{1}{-100} - \frac{1}{\infty} = \frac{1}{f}$$

$$f = -100 \text{ cm} = -1 \text{ m.}$$

\therefore Power of lens,

$$P = \frac{1}{f(m)} = \frac{1}{-1} = -1\text{D.}$$

31. i. Cooking oil gets oxidized when comes in contact with air and gives a bad smell or turns "rancid". The oxygen present in the chips packet is replaced by flushing nitrogen in the packet, this in turn puffs up the packet.
 ii. Iron easily reacts with atmospheric oxygen in presence of slight moisture to give iron oxide. In this process of 'corrosion', the outer layer of iron is oxidized and hence sacrificed leading to the shaping of the iron article. To avoid this oxidation, the article is coated with paint so as to make a barrier between the article's surface and atmosphere.
32. a. Genotype of man: Bb (Heterozygous)
 Genotype of mother: bb
 (homozygous recessive)
 b. Possible genotype of his father: Bb (Heterozygous) or BB (homozygous dominant)
 c. Cross between heterozygous man and homozygous recessive blue-eyed woman Bb x bb 50% Blue-eyed
 50% Brown eyed.

The ratio obtained is 1 : 1 it is an example of test cross also.

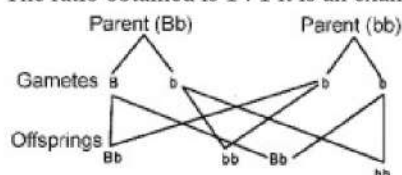

OR

Contrasting traits were used by Mendel and were classified as dominant or recessive. Mendel used 7 traits of pea plant for his experiments. Out of which 3 are.

Character	Given Trait	Contrasting Trait
(i) Position of flower	Terminal	Axial (dominant)
(ii) Colour of flower	White	Violet (dominant)
(iii) Shape of pod	Constricted	Full (dominant)

33. This is because of scattering of light near the horizon, most of the blue light and shorter wavelengths are scattered away by the particles present in the atmosphere during sunrise and sunset. So, the light that reaches our eyes is of longer wavelength (e.g. red). This gives rise to the reddish appearance of the sky. But during the day sun appears white as sun is near the surface of earth nearly overhead, thus the sunlight passes through much smaller distance and thus the scattering is much less and sun appears white.

Section D

34. i) The ore is Cinnabar (Hg_2S)

Cinnabar is the ore of mercury (Hg) which has low reactivity and can be reduced to mercury by heating alone. So to obtain mercury from cinnabar the only step required is heating strongly in the presence of oxygen called "Roasting". In the first step, cinnabar gets converted to mercuric oxide which on further heating is reduced to mercury.

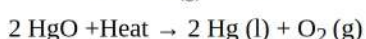
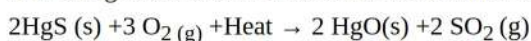

ii) a. This reaction will take place as Zn is more reactive than Cu, so Zn will displace Cu from its salt CuSO_4 and will form colourless ZnSO_4 solution and reddish brown particles Cu.

b. This reaction will not occur as Fe is less reactive than Zn, so it will not be able to displace Zn from ZnSO_4 .

OR

Let the atomic mass of alkali metal A be x. According to the question, the metal A reacts with water and forms a compound B of molecular mass 40.

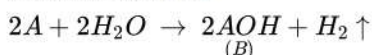

According to the question,

$$x + 16 + 1 = 40$$

$$\therefore x = 40 - 17 = 23$$

and, 23 is the atomic mass of sodium(Na). Therefore, the alkali metal (A) is Na and the reaction is written below:

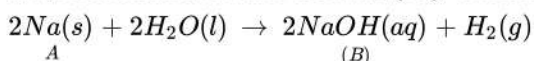

So, compound B is sodium hydroxide (NaOH). Sodium hydroxide reacts with aluminium oxide (Al_2O_3) to give sodium aluminate (NaAlO_2).

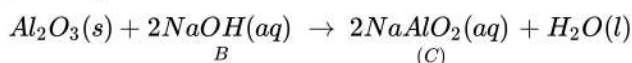

Thus, compound C is sodium aluminate (NaAlO_2).

35. i. Kidneys are located in the abdomen, one on either side of the backbone.
 ii. The excretory system removes the poisonous waste substances from the body in the form of urine and maintains ionic balance called osmoregulation.
 iii. Urine produced in the kidneys passes through the ureters into the urinary bladder where it is stored until it is released through the urethra.
 iv. During filtration, the substance like glucose, amino acids, salts, water, urea, etc. present in the blood pass into Bowman's capsule and then enter the tubule of the nephron.
 v. The waste substances like urea, some unwanted salts and excess water remain behind in the tubule which forms the yellowish liquid called urine.

OR

Liver is the largest gland in human beings.

Its main functions are as follows:

- (i) It secretes bile juice which makes the medium of the food alkaline and also emulsifies fat.
 (ii) It stores the excess of glucose in the form of glycogen.
 (iii) Old worn-out RBCs are broken down in liver cells. Their haemoglobin is changed into bile pigments.
 (iv) The ammonia is produced as a result of metabolism of amino acids in the liver. It is highly toxic. The ammonia combines with CO_2 and is converted into urea (less toxic).
 (v) It stores vitamins, iron and copper.
 (vi) It produces heparin which does not allow the clotting of blood inside the blood vessels.
 (vii) RBCs are produced at the foetus stage by the liver.

I	II
Current (I) shows Direct Current (D.C.).	Current (II) shows Alternating Current (A.C.).
Current D.C flows in one direction only. It is called a direct current. The magnitude and direction of the flow of current remain the same.	Current A.C reverses direction after equal intervals of time. It is called alternating current. The magnitude and direction of current change continuously at definite intervals of time.
The magnitude of current in D.C does not become zero with the passage of time.	The magnitude of A.C becomes zero after a regular time interval.

- b. Source of (I) D.C. → A cell, battery, D.C. generator,
 Source of (II) A.C. → A.C. generator.

Section E

37. Read the text carefully and answer the questions:

Two or more resistances are connected in series or in parallel or both, depending upon whether we want to increase or decrease the circuit resistance.

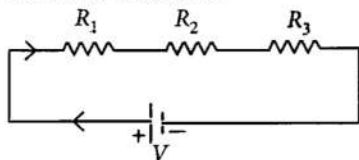

The two or more resistances are said to be connected in series if the current flowing through each resistor is the same.

(i) In series combination, $R_s = R_1 + R_2 + R_3 = R + R + R = 3R$.

(ii) The equivalent resistance is where the total resistance is connected either in parallel or in series.

Resistance of each wire = $\frac{20}{4} = 5 \Omega$

Equivalent resistance in series

$R_s = 5 + 5 + 5 + 5 = 20 \Omega$

OR

All are in series, $R_s = 5R = 5 \times 2 = 10 \Omega$

38. Read the text carefully and answer the questions:

You must have noticed many dramatic changes in your appearance as well as that of your friends as you approached 10-12 years of age. These changes associated with puberty are because of the secretion of testosterone in males and oestrogen in females. Do you know anyone in your family or friends who has been advised by the doctor to take less sugar in their diet because they are suffering from diabetes? As a treatment, they might be taking injections of insulin. This is a hormone that is produced by the pancreas.

- (i) Pancreas is a dual gland because it acts as both an endocrine and exocrine gland. As endocrine, it secretes hormones like insulin, glucagon. As an exocrine gland, it releases enzymes like trypsin, lipase, amylase etc.
- (ii) Testosterone in males and oestrogen in females is the hormone that is secreted during adolescence.
- (iii) If Insulin is not secreted in the proper amount then it causes diabetes.

OR

Glucagon and Insulin are secreted from alpha and beta cells of islets of the pancreas respectively.

39. Read the text carefully and answer the questions:

Salt of a strong acid and strong base is neutral with a pH value of 7. NaCl common salt is formed by a combination of hydrochloride and sodium hydroxide solution. This is the salt that is used in food. Some salt is called rock salt, bed of rock salt was formed when seas of bygone ages dried up. The common salt thus obtained is an important raw material for various materials of daily use, such as sodium hydroxide, baking soda, washing soda, and bleaching powder.

- (i) Carbonic acid does not form an acidic salt.
- (ii) Sodium bicarbonate, commonly known as baking soda or bicarbonate of soda, is a chemical compound with the formula NaHCO_3 .
- (iii) Ca(OH)_2 treatment with chlorine to obtain bleaching powder.



OR

Washing soda is used for removing the permanent hardness of the water.